

Silgan White Cap 200

 They have extensive know-how. They have the ability to look ahead and understand the customer's needs from the point of view of technical specifications.

★★★

The Silgan White Cap 200 is the sophisticated technical solution for low and medium production speeds of up to 300 caps per minute.

Features

- Open frame made of top-quality stainless steel for optimal cleaning and minimum maintenance
- Capping rates of up to 300 jars per minute for Press-On® closures and Twist-Off® lug caps

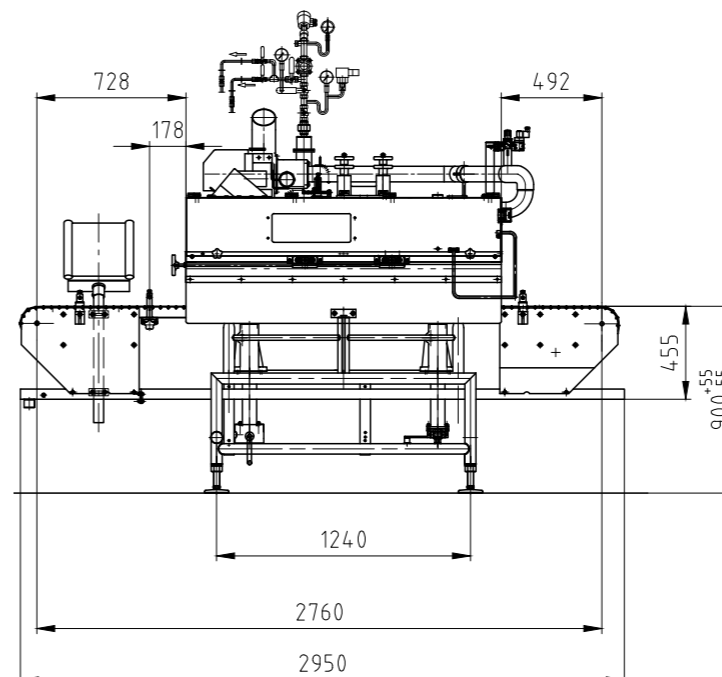
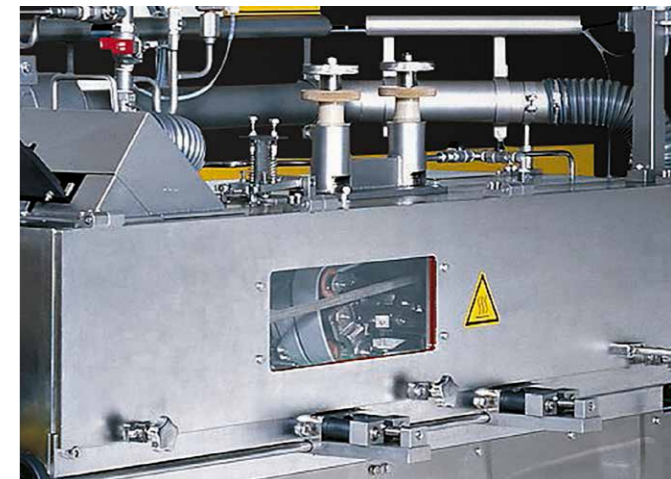

Electrical requirements

400 V
50/60 Hz
2.5 kW

Steam requirements

5 – 8 bar
30 – 90 kg/h

Steam supply line connection

R 3/4"
Exhaust pipe
Ø 150 mm minimum

Preferably soft water

R 1/4"
0.25 m³/h

Max. line speed

300 per min. for PT
300 per min. for Twist-Off®

Closure types

Suitable for all Twist-Off®
& PT closure types with
27 – 100 mm



Min. 40 mm
Max. 280 mm



Min. 40 mm
Max. 160 mm