

# Silgan White Cap 600-1



 Silgan always responds to a complaint right away, and they try to solve and fix it as quickly as possible.  
 ★★ ★

The Silgan White Cap 600-1 provides just the right machine concept for all customers with stringent requirements in respect of capping performance and efficiency as well as hygiene and cleanliness. It is ideally suited for fast line speeds of up to 1000 PT closures per minute and enables capping rates of up to 850 jars per minute for Twist-Off® lug caps.

**Features:**

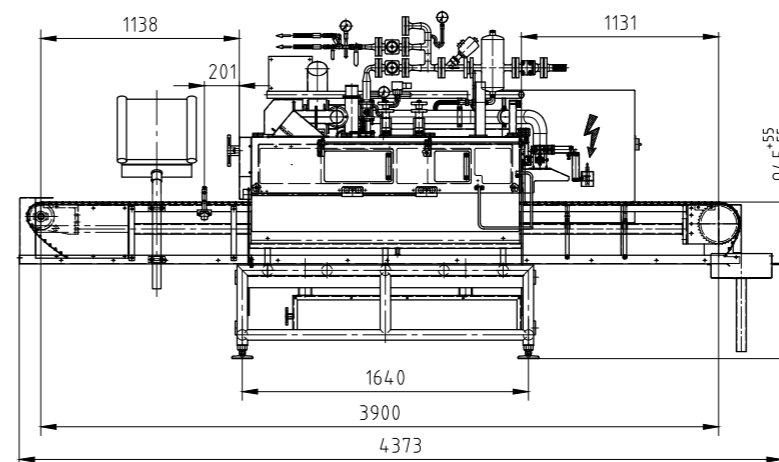
- Open frame design with top-quality stainless steel for optimal cleaning and minimum maintenance
- Quick change-over and easy set-up
- Electronic adjustment to different jar heights
- Completely new electrical components: smaller electrical cabinet, touch panel, servo drive, IE5-classified
- Available in right- or left-handed configuration



<p><b>Electrical requirements</b>                  400 V                  50/60 Hz                  7.5 kW</p>	<p><b>Machine connection</b>                  DN25                  Exhaust pipe                  Ø 150 mm minimum</p>	<p><b>Max. line speed</b>                  1.000 per min. for PT                  850 per min. for Twist-Off®</p>	<p> Min. 40 mm                  Max. 300 mm</p>
<p><b>Steam requirements</b>                  5 – 8 bar                  50 – 120 kg/h</p>	<p><b>Preferably soft water</b>                  R 1/4"                  0.25 m³/h</p>	<p><b>Closure types</b>                  Suitable for all Twist-Off®                  &amp; PT closure types with                  27 – 100 mm</p>	<p> Min. 40 mm                  Max. 160 mm</p>