

Silgan White Cap 150

 When you have technological problems, we call them and Silgan gets back to us quickly –
 ★★★ either within half an hour or an hour.



The Silgan White Cap 150 is the perfect solution for flexible and safe production capping machines. It provides an alternative option to the standard cappers in terms of performance, shape and functionality – including Silgan engineering expertise and cutting-edge technology.

Features

- Output of 100 to 150 jars per minute
- Suitable for all Twist-Off® 27 to 100 mm diameter sealing food glass jars
- Complies with the latest hygiene standards
- Stainless steel
- CE-compliant

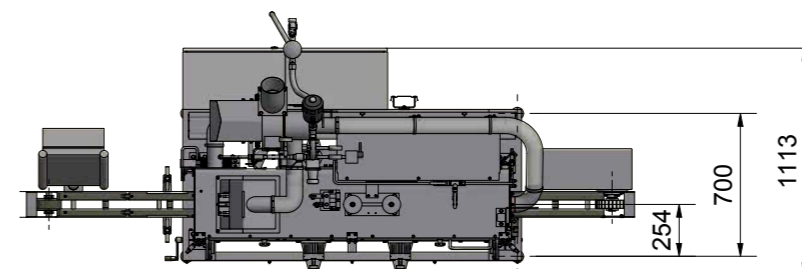
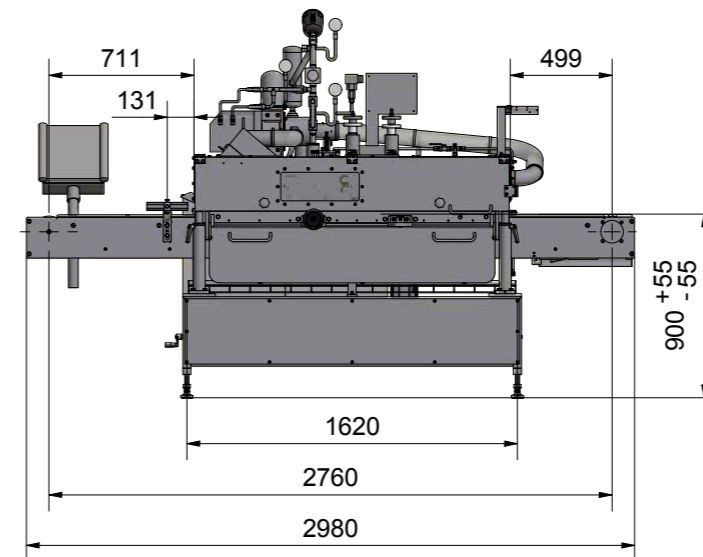

Electrical requirements

400 V
50 / 60Hz
2.5 kW

Steam requirements

5 – 8 bar
30 – 90 kg/h
R 3/4"

Steam supply line connection

R 3/4"
Exhaust pipe
Ø 150 mm minimum

Preferably soft water

R 1/4"
0.25 m³/h

Max. line speed

150 per min. for Twist-Off® and PT

Closure types

Suitable for all Twist-Off® & PT closure types with 27 – 100 mm



Min. 40 mm
Max. 300 mm



Min. 40 mm
Max. 160 mm